

P-250iB



Max. load capacity at wrist: 15 kg



Max. reach: 2800 mm

FANUC

Design

The P-250iB is the industry's most flexible and advanced six-axis paint robot available on the market.

Working range P-250iB

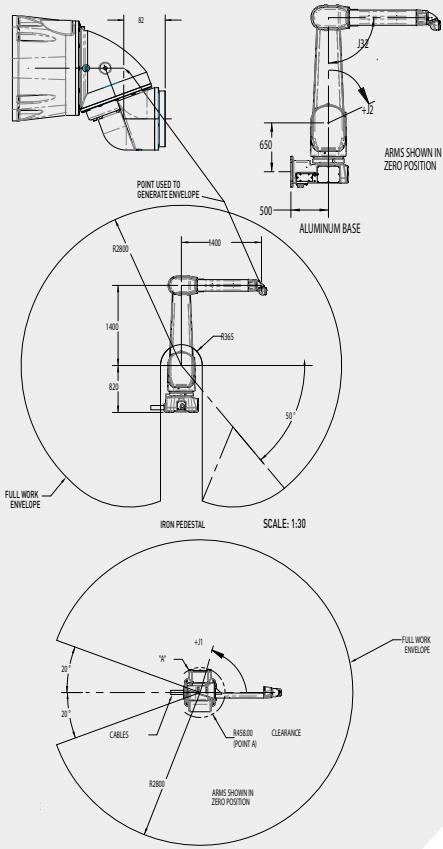

Features

- Standard process hose routing and management
- Options for single or dual integrated process axis motors on the outer arm
- Optional Nylon-12 non-conductive outer arm and wrist available
- Optional seventh-axis rail for larger envelope requirements
- Standard integrated diagnostic and reporting capabilities
- “Flip-Over” capability provides the industry's largest work envelope
- Balanced arm design provides excellent near reach and stroke length
- Built-in process parameter diagnostic monitoring and reporting provides integrated real-time strip chart capability
- Supports all major network communication protocols

Options

- Floor, wall, angle, and ceiling mount configurations
- Easily configured left hand or right hand arm to maintain symmetry across the booth
- Designed for ease of maintenance and easy access to all critical components
- High arm and wrist payload design supports a variety of applications including rotary atomizers, conventional and electrostatic spray guns and multi-gun configurations

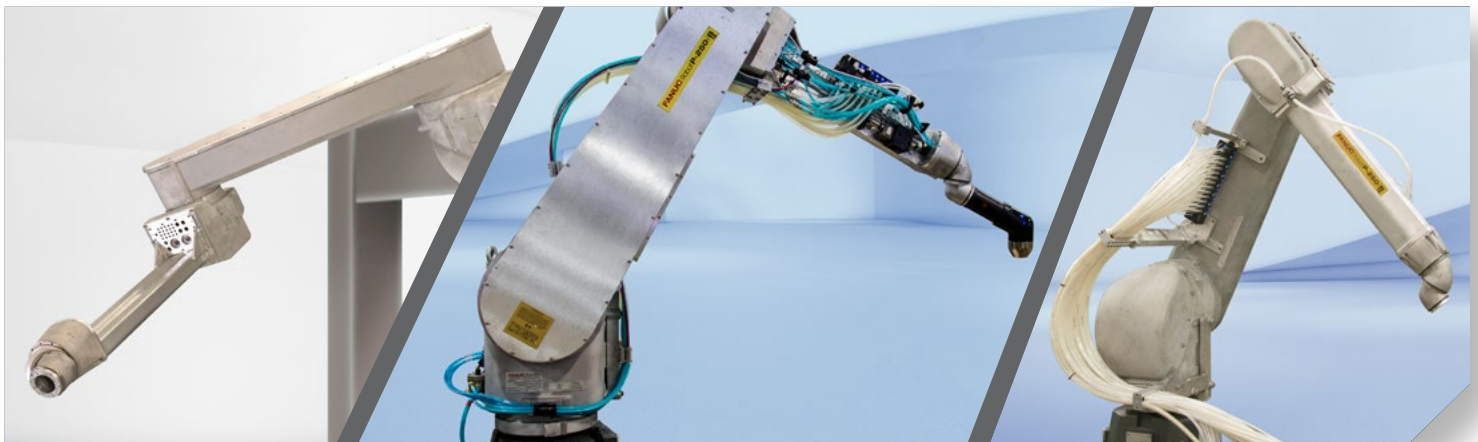

P-250iB



Max. load capacity at wrist: 15 kg



Max. reach: 2800 mm

FANUC

Robot			Max. load capacity at wrist (kg)	Reach (mm)	Controlled axes	Repeatability (mm)	Mechanical weight (kg)	Motion range [°]						Maximum speed [°/s]						Allowable load moment at wrist (Nm) Allowable load inertia at wrist (kg m ²)			Input power source (VAC) (50-60 HZ)
Series	Version	Type						J1	J2	J3	J4	J5	J6	J1	J2	J3	J4	J5	J6	J4	J5	J6	
P-250	iB	-	15	2800	6	± 0.07	530	320	280	330	1080	1080	1080	160	160	160	375	430	545	65 3	55 2.1	11.5 .35	380-575 +10/-15%

P-250iB Paint robot



P-250iB

